

3D PrintPRO 2

Last Updated on 08.04.2021



For open framed 3D printers.

The BOFA 3D PrintPRO 2 is a low cost unit, which extracts fumes generated by an open framed 3D printer without causing the filament deposition area to be cooled.

It has the benefits of low noise level and minimal power consumption. Each unit can be supplied with a connection hose, 'Stay Put' arm and conical shaped funnel.

Print your own extendable manifolds 3D drawing files can be found at:
bofainternational.com/en/print-your-own

Technology



HEPA filter



Advanced carbon
filter (ACF)
technology



Multi voltage
sensing unit (MVS)



ProTECT service
plan



SureCHECK
quality standard

Key features of the 3D PrintPRO 2

Filter change indicator
Standard

Hose kit included
Optional

Powder coated for durability
Standard

Compact size
Standard

3 level filtration - pre, HEPA and chemical filters
Standard

Low noise level
Standard

Small footprint
Standard

24V remote stop/ start interface
Optional

Contact BOFA at <https://bofainternational.com/en/contact/>

<https://bofainternational.com/en/portal/datasheets/3d-printpro-2/>

Technical specification

- 1. Filter change indicator
- 5. Lid fastening latches

- 2. On / Off switch
- 6. Hose inlet connections - 50mm

- 3. Feet
- 7. Exhaust outlets

- 4. Power cable inlet

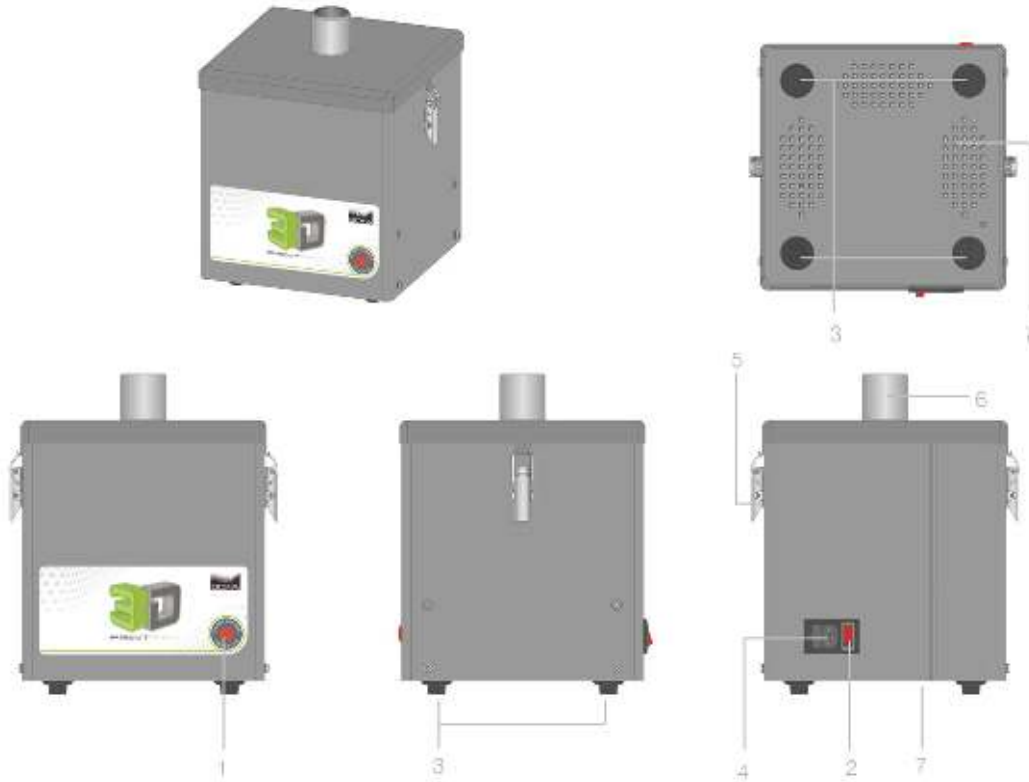

Optional Hose kit technical specification

- 1. Funnel
- 5. 2 x 'G' clamps

- 2. 50mm 'Stay Put' arm
- 6. 60mm flexible hose

- 3. Fliptop mount
- 7. 2 x jubilee clamp

- 4. Table bracket
- 8. Shut off valve

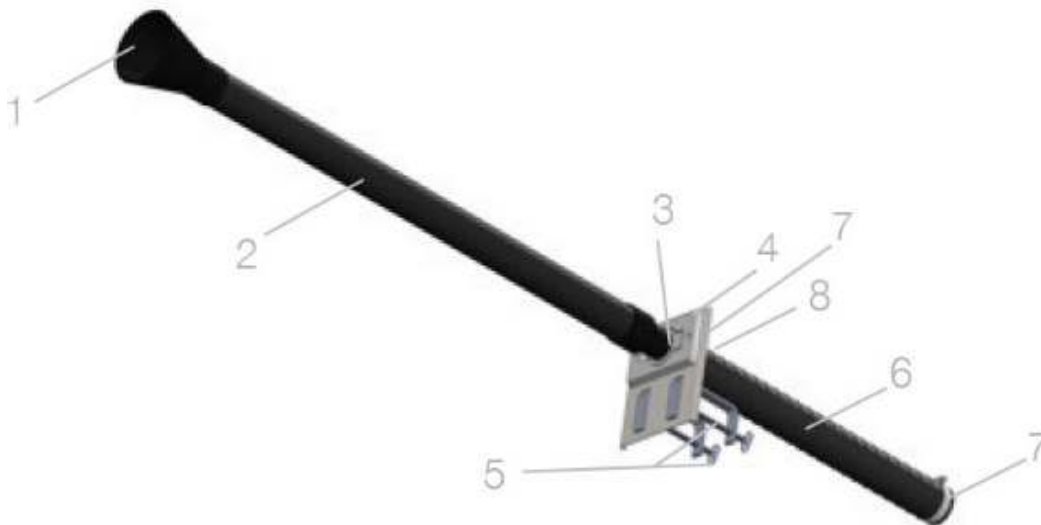

Airflow through filters

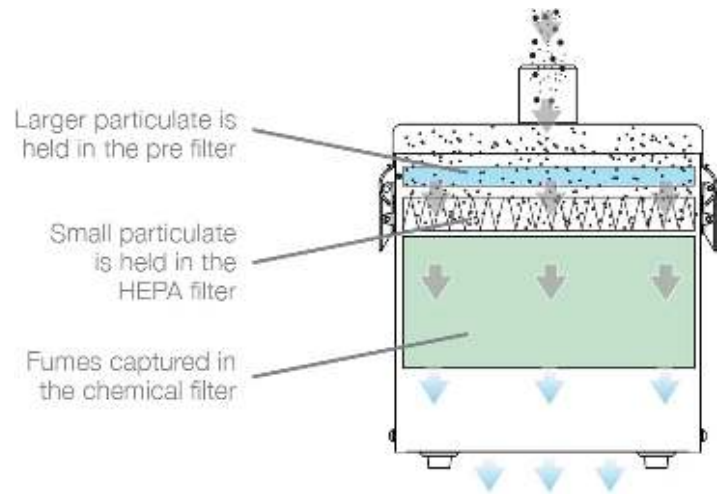
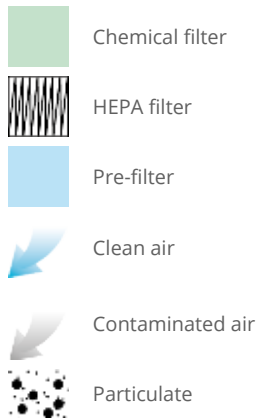

Technical data

	EU	US
Dimensions (HxWxD)	330 x 290 x 270mm	12.99 x 11.42 x 10.63"
Cabinet construction	Powder coated mild steel	Powder coated mild steel
Airflow / pressure	45m ³ /hr	26.5cfm
Electrical data	230v Single-phase 1~ 50/60Hz Full load current: 0.2 amps	115v 60/50Hz Full load current: 0.2 amps
Noise level	< 44dBA (at typical operating speed)	< 44dBA (at typical operating speed)
Weight	7.8kgs	17lbs
Approvals	UKCA and CE	UKCA and CE

Pre-filter specifications

Filter media	Borosilicate
Filter media construction	Pad
Filter efficiency	96% @ 2 microns

Combined HEPA / Gas filter specifications

HEPA filter media	Borosilicate
HEPA media construction	Maxi pleat construction with glue bead spacers
Gas filter	Treated activated carbon
Filter housing	Zintec mild steel
Filter efficiency	99.997% @0.3 microns

Unit part numbers

Model	Part number	Optional 24v Stop/Start
3D PrintPRO 2 Powder coated	L5444-0000	A2001
3D PrintPRO 2 Powder coated + install kit & arm	L5444-0002	A2001

Replacement filter part numbers

Model	Pre-filter	Combined HEPA/Gas filter
3D PrintPRO 2	A1030102	A1030099

Datasheet correct at time of publishing.

Where applicable, the carbon used in BOFA units is capable of removing a wide range of VOC's, however it is the responsibility of the user to ensure the carbon is suitable for their application. For specific applications, please contact us for details.

Think before you print! Please consider the environment before printing this document.



MJB - 18 avenue du Gué Langlois – 77600 BUSSY ST MARTIN
Tel : 01.64.62.68.00 Fax : 01.64.62.70.87
Mail: infoMJB@mjb.fr - www.mjb.fr