



A Donaldson Company

A WORLD LEADER IN FUME  
EXTRACTION TECHNOLOGY

## FumeCAB 1000 iQ

ELECTRONICS, PHARMACEUTICAL & MEDICAL

Last Updated on 14.09.2018



The complete cabinet fume extraction solution for a broad range of applications.

Partial enclosures are becoming the recommended extraction option for a variety of applications. Government bodies, including the HSE are now making direct reference through guidance documentation such as the HSG258 to their use.

The FumeCAB 1000 iQ integrated filtration system has been designed to ensure compliance with the latest regulations. It provides users with an extra depth of working space for taller applications.

BOFA's iQ Operating System and ultrabright slimline energy saving LED lights come as standard making this system an ideal choice of fume extraction for a wide variety of applications.

More information about the [Intelligent \(iQ\) Operating System](#).

### Technology



Intelligent (iQ)  
Operating System



HEPA filter



Automatic flow  
control (AFC)  
technology



Reverse flow air  
(RFA) technology



Advanced carbon  
filter (ACF)  
technology



Patented  
technology



ProTECT service  
plan



SureCHECK  
quality standard

### Key features of the FumeCAB 1000 iQ

Certified to BS 7989:2001 Recirculatory filtration fume cabinet specification Standard

Reverse flow filter technology Standard

Ensures operational compliance with HSG258 guidelines Standard

Automatic flow control system Standard

Contact BOFA at <https://bofainternational.com/en/contact/>

<https://bofainternational.com/en/portal/datasheets/fumecab-1000-iq/>



**Energy saving ultra-bright slim line LED lighting**  
Standard

**Combined HEPA/Gas filter incorporating ACF technology**  
Standard

**Real time airflow reading**  
Standard

**High contrast display**  
Standard

**Remote diagnostics via USB**  
Standard

**Side entry blind grommets for equipment access**  
Standard

**Interfacing**  
Optional

**Stand**  
Optional

**Twin coated anti UV / anti splash protective Polycarbonate visor**  
Standard

**Filters with long life and low replacement cost**  
Standard

**Independent filter condition monitoring, display and warnings**  
Standard

**'Run safe' operation**  
Standard

**Large working area**  
Standard

**VOC gas sensor (Volatile Organic Compound)**  
Optional

**UV lighting**  
Optional

**Optional filter medias**  
Optional

### Technical specification

1. iQ display

2. On / Off switch

3. Filter compartment hinges

4. Cable entry grommet

5. Transparent visor

6. Hinges

7. Mains inlet

8. LED lighting

9. Exhaust

10. Cooling air inlet

11. Standby button

12. UV lighting (optional)



Left Side / Internal work area

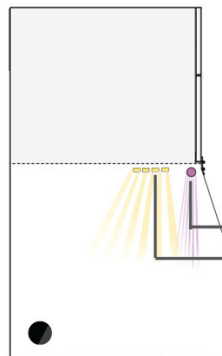

Back

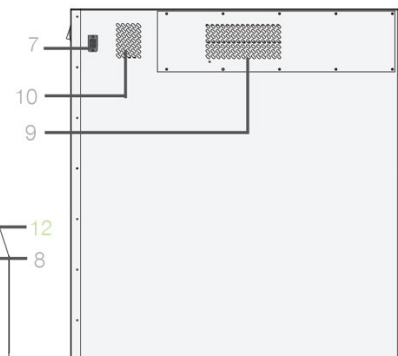

## Internal work area and optional stand

### 13. Stand (optional)

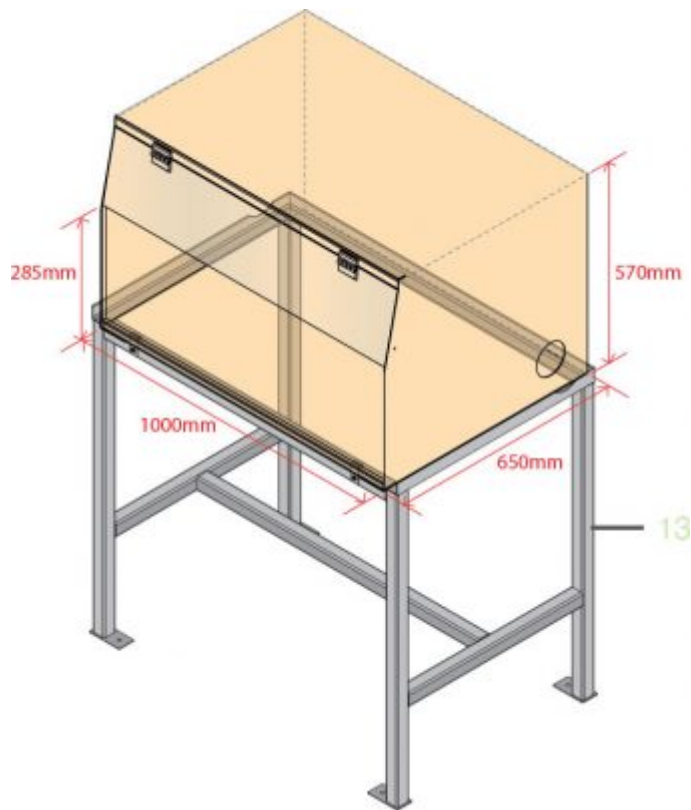

### Airflow through filters

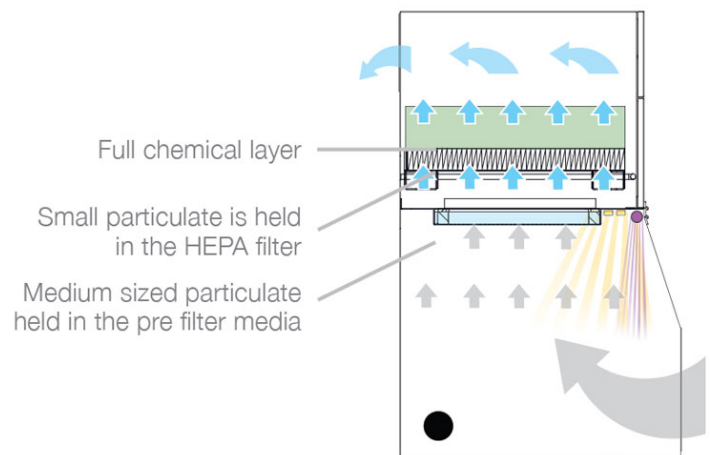
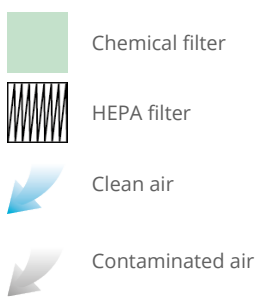

### Technical data

|                            | EU                       | US                       |
|----------------------------|--------------------------|--------------------------|
| Dimensions (HxWxD)         | 1003 x 1000 x 655mm      | 39.49 x 39.37 x 25.79"   |
| Opening dimensions (HxWxD) | 285 x 1000 x 650mm       | 11.2 x 39.4 x 25.6"      |
| Cabinet construction       | Powder coated mild steel | Powder coated mild steel |
| Face velocity              | 0.4m/s                   | 78.7ft/min               |

| Technical data            |  |   |
|---------------------------|--|---|
| Max face velocity         | 0.6m/s                                 | 118ft/min                               |
| Electrical data           | 230v 50/60Hz Full load current: 6 amps | 115v 50/60Hz Full load current: 10 amps |
| Noise level               | < 60dBA (At typical operating speed)   | < 60dBA (At typical operating speed)    |
| Weight                    | 120kg                                  | 264lbs                                  |
| Exhaust outlet (Optional) | 125mm                                  | 125mm                                   |
| Approvals                 | CE                                     | CE                                      |

| Pre filter specifications |                   |
|---------------------------|-------------------|
| Filter media construction | Filter pad        |
| Filter housing            | Cardboard         |
| Filter efficiency         | 99% @ 0.3 microns |

| Combined HEPA/Gas filter specifications |  |
|---|--|
| HEPA filter media                       | Glass fibre                                  |
| HEPA media construction                 | Maxi pleat construction with webbing spacers |
| Filter housing                          | Zintec mild steel                            |
| Treated activated carbon                | 17kgs (37.4 lbs)                             |
| Filter efficiency                       | 99.997% @ 0.3 microns                        |

| Optional stand specifications |  |
|-------------------------------|--|
| Dimensions (HxWxD)            | 943 x 1029 x 669mm / 37.1 x 40.5 x 26.3" |
| Stand Construction            | Powder coated mild steel                 |

| Unit part numbers                |         |          |
|----------------------------------|---------|----------|
| Model                            | Voltage | Part No. |
| FumeCAB 1000 iQ<br>Powder coated | 230V    | E2242A   |
| FumeCAB 1000 iQ<br>Powder coated | 115V    | E2241A   |

| Replacement filter part numbers |          |
|---------------------------------|----------|
| Model                           | Part no. |
| Pre Filter                      | A1030249 |
| Combined Filter                 | A0130250 |

*Datasheet correct at time of publishing.*

*Where applicable, the carbon used in BOFA units is capable of removing a wide range of VOC's, however it is the responsibility of the user to ensure the carbon is suitable for their application. For specific applications, please contact us for details.*



*Think before you print! Please consider the environment before printing this document.*



MJB - 18 avenue du Gué Langlois – 77600 BUSSY ST MARTIN  
Tel : 01.64.62.68.00 Fax : 01.64.62.70.87  
Mail: [infoMJB@mjb.fr](mailto:infoMJB@mjb.fr) - [www.mjb.fr](http://www.mjb.fr)